

AT G.L. LC NO. 27'C

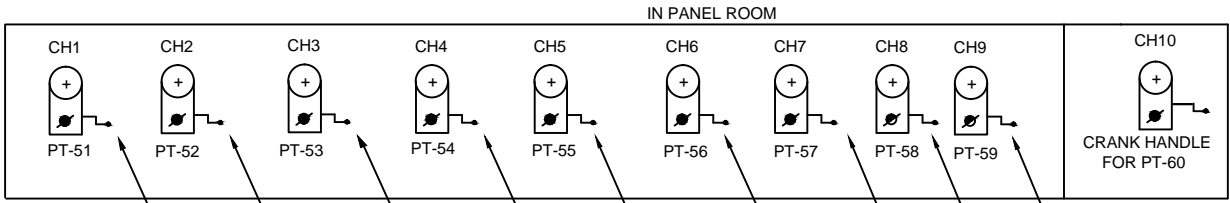
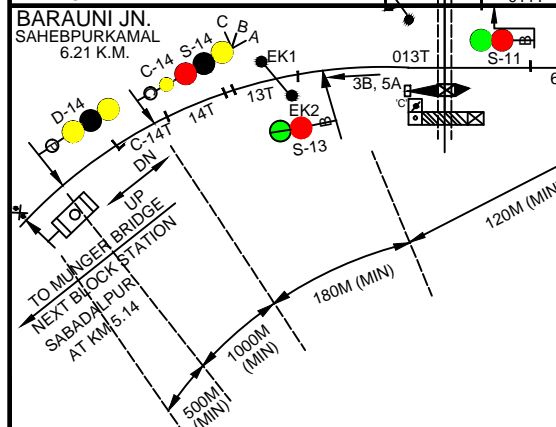
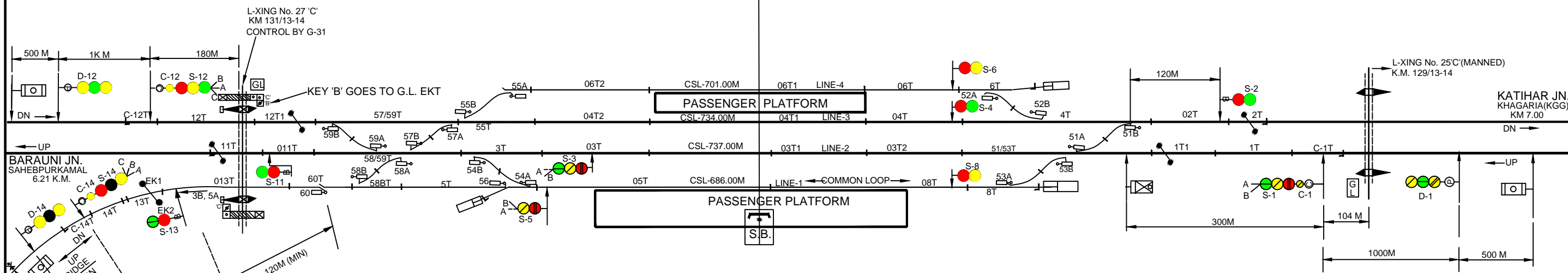
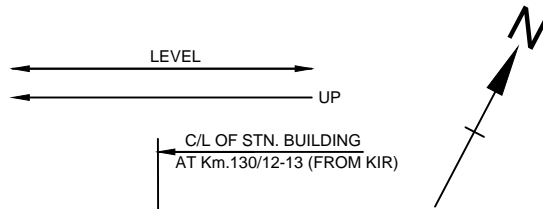
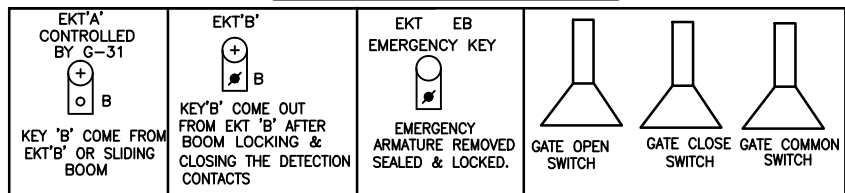

CRANK HANDLE WELDED WITH THE KEY

- PANEL DETAILS:-
- MAIN SIGNAL BUTTONS 1,2,3,4,5,6,8,11,12,13,14
 - CALLING-ON SIGNAL BUTTONS C-1,C-12,C-14
 - POINT CONTROLL BUTTONS 51,52,53,54,55,56,57,58,59,60
 - CRANK HANDLE CONTROLL BUTTONS CH-1,CH-2,CH-3,CH-4,CH-5,CH-6,CH-7,CH-8,CH-9,CH-10
 - L-XING GATE CONTROL BUTTON G-31

- NOTE:-
1. ABSOLUTE BLOCK SYSTEM OF WORKING WITH KHAGARIA , SAHEBPURKAMAL & SABDALPUR Jn.
 2. DLBI WORKING WITH KHAGARIA & SAHEBPURKAMAL SITUATED IN PANEL CABIN.
 3. MAGNETO TELEPHONE PROVIDED BETWEEN PANEL ROOM & GATE No. 25'C & 27'C
 4. CONTROL TELEPHONE PROVIDED IN PANEL ROOM
 5. AXLE COUNTER PROVIDED FOR LAST VEHICLE VERIFICATION AND INTERLOCKED WITH BLOCK INSTT.
 6. PROVISION OF SLIDING BOOM & EOLB AT L.C. NO. 27'C.
 7. THE SIGNALLING INSTALLATION IS SUITABLE FOR 25 KV AC TRACTION.
 8. SINGLE LINE FM TYPE TOKEN LESS BI BETWEEN UMESHNAGAR & SABDALPUR.